

This datasheet is valid for following parts:

- HTPA32x32dL2.1/0.8HiC[Si]**
- HTPA32x32dL2.1/0.8C[Si]**
- HTPA32x32dL2.1/0.8HiS[Si]**
- HTPA32x32dL2.1/0.8S[Si]**
- HTPA32x32dL2.1/0.8F5.0HiC[Si]**
- HTPA32x32dL2.1/0.8F5.0C[Si]**
- HTPA32x32dL2.1/0.8F5.0HiS[Si]**
- HTPA32x32dL2.1/0.8F5.0S[Si]**

1 Principal Schematic for HTPA32x32d:

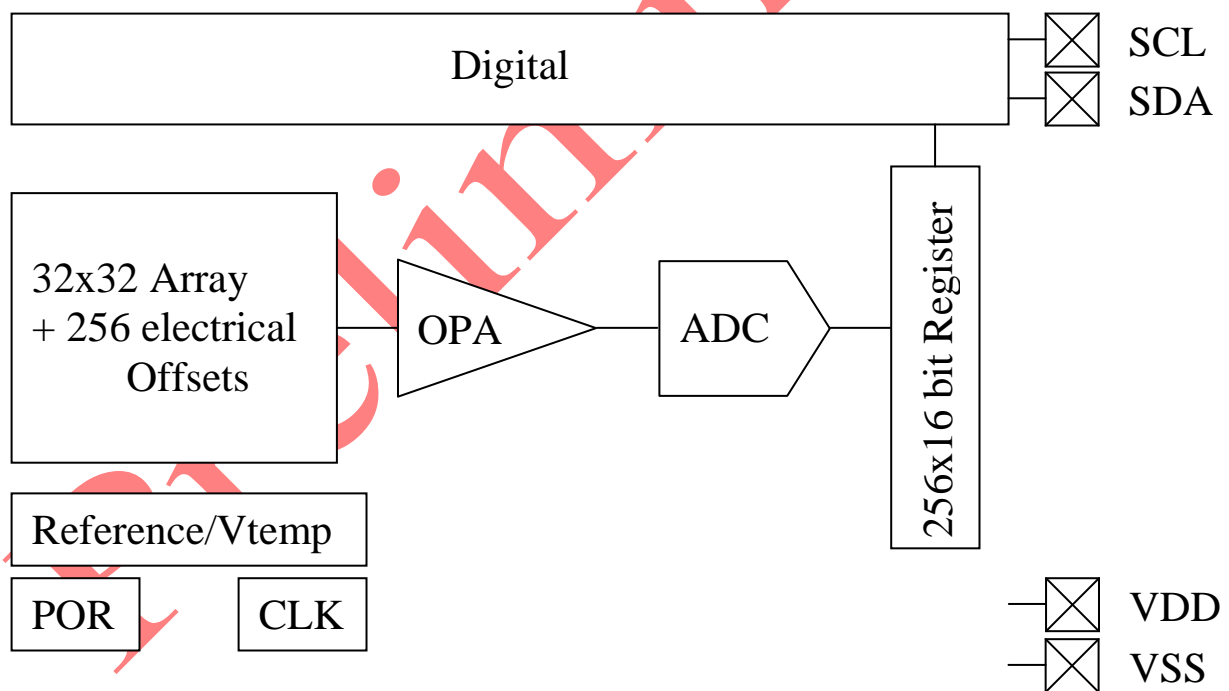

Pin Assignment– Bottom View:

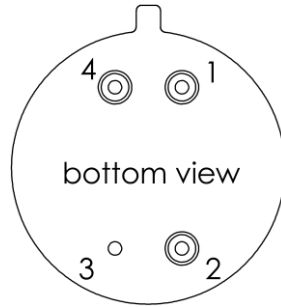
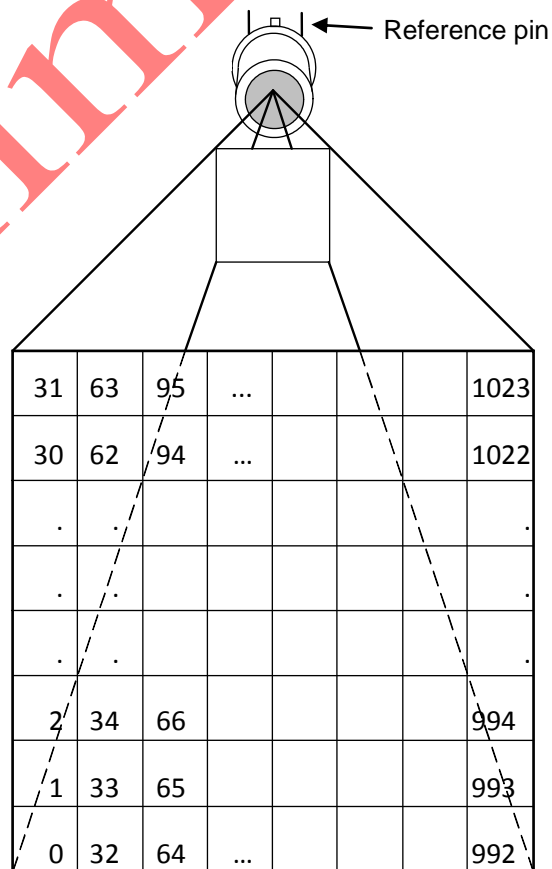

Figure 1: pin-allocation

Pin	Symbol	Description
1	SCL	Digital I/O, Open Drain, 100k PU, Serial Clock
2	VDD	Positive supply voltage
3	VSS	Negative supply voltage / Ground (0V) (connected to housing)
4	SDA	Digital I/O, Open Drain, 100k PU, Serial Data

2 Optical Orientation:



3 Order Code Example

HTPA32x31	S	L10 / 0.8	F8-14	e	Hi	M	(SPD)	[Si]
-----------	---	-----------	-------	---	----	---	-------	------

Type: HTPA32x31	Please contact support for all available HTPA and module combinations.
Package: S Not declared	SMD variant TO can variant
Output: d Not declared	HTPA sensor with digital output HTPA sensor with analogous output
Optics: L /	Focal length: In example L10 = 10.0 mm focal length F-Number: In example /0.8 For optics see also "HTPA standard optics"
Filter: F Not declared	Filter characteristics. In example F8-14 (µm, Bandpass) Broad band ARC
External aperture: Not declared e	without external aperture with external aperture
Sensitivity: Hi Not declared	Increased sensitivity Standard sensitivity
Version: A C M S	Application set: comes with GUI, housing, power supply. Always UDP Interface. Calibrated sensor (only digital). Carries calibration constants on internal EEPROM Module: HTPA sensor soldered to PCB, calibrated stream HTPA sensor only. Raw voltage output, not calibrated
Interface: SPI LC UDP PoE	SPI device; Three variants: HTPA82x62: 16bit ADC all other analogous HTPAs: 14bit ADC Digital HTPA: 12bit ADC SPI, Only Analogous HTPA, 12bit ADC low speed, external processing required Ethernet, CAT5 cable connection Power over Ethernet, CAT5 connection, UDP protocol
Lens Material: Si Not declared	Silicon Germanium



HTPA32x32dL2.1/0.8

Thermopile Array With Lens Optics

Rev.8: 2016.04.12 Schnorr



4 Serial Order of Frame

The sensor is divided into two parts (top and bottom half) which are again separated into 4 blocks. The readout order is shown below for the different blocks.

Block 0 (top)
Block 1 (top)
Block 2 (top)
Block 3 (top)
Block 3 (bottom)
Block 2 (bottom)
Block 1 (bottom)
Block 0 (bottom)

Whenever a conversion is started the Block x of the top and bottom half are measured at the same time. Each block consists of 128 Pixel that are sampled fully parallel. The readout order on the bottom half is mirrored compared to the top half so that the central lines are always read last.

32x32d active Pixel																																readout order top ↑ readout order bottom
0	1	2	3	4	5	6	7	8	9	10	11	12	13	14	15	16	17	18	19	20	21	22	23	24	25	26	27	28	29	30	31	
32	33	34	35	36	37	38	39	40	41	42	43	44	45	46	47	48	49	50	51	52	53	54	55	56	57	58	59	60	61	62	63	
64	65	66	67	68	69	70	71	72	73	74	75	76	77	78	79	80	81	82	83	84	85	86	87	88	89	90	91	92	93	94	95	
96	97	98	99	100	101	102	103	104	105	106	107	108	109	110	111	112	113	114	115	116	117	118	119	120	121	122	123	124	125	126	127	
128	129	130	131	132	133	134	135	136	137	138	139	140	141	142	143	144	145	146	147	148	149	150	151	152	153	154	155	156	157	158	159	
160	161	162	163	164	165	166	167	168	169	170	171	172	173	174	175	176	177	178	179	180	181	182	183	184	185	186	187	188	189	190	191	
192	193	194	195	196	197	198	199	200	201	202	203	204	205	206	207	208	209	210	211	212	213	214	215	216	217	218	219	220	221	222	223	
224	225	226	227	228	229	230	231	232	233	234	235	236	237	238	239	240	241	242	243	244	245	246	247	248	249	250	251	252	253	254	255	
256	257	258	259	260	261	262	263	264	265	266	267	268	269	270	271	272	273	274	275	276	277	278	279	280	281	282	283	284	285	286	287	
288	289	290	291	292	293	294	295	296	297	298	299	300	301	302	303	304	305	306	307	308	309	310	311	312	313	314	315	316	317	318	319	
320	321	322	323	324	325	326	327	328	329	330	331	332	333	334	335	336	337	338	339	340	341	342	343	344	345	346	347	348	349	350	351	
352	353	354	355	356	357	358	359	360	361	362	363	364	365	366	367	368	369	370	371	372	373	374	375	376	377	378	379	380	381	382	383	
384	385	386	387	388	389	390	391	392	393	394	395	396	397	398	399	400	401	402	403	404	405	406	407	408	409	410	411	412	413	414	415	
416	417	418	419	420	421	422	423	424	425	426	427	428	429	430	431	432	433	434	435	436	437	438	439	440	441	442	443	444	445	446	447	
448	449	450	451	452	453	454	455	456	457	458	459	460	461	462	463	464	465	466	467	468	469	470	471	472	473	474	475	476	477	478	479	
480	481	482	483	484	485	486	487	488	489	490	491	492	493	494	495	496	497	498	499	500	501	502	503	504	505	506	507	508	509	510	511	
512	513	514	515	516	517	518	519	520	521	522	523	524	525	526	527	528	529	530	531	532	533	534	535	536	537	538	539	540	541	542	543	
544	545	546	547	548	549	550	551	552	553	554	555	556	557	558	559	560	561	562	563	564	565	566	567	568	569	570	571	572	573	574	575	
576	577	578	579	580	581	582	583	584	585	586	587	588	589	590	591	592	593	594	595	596	597	598	599	600	601	602	603	604	605	606	607	
608	609	610	611	612	613	614	615	616	617	618	619	620	621	622	623	624	625	626	627	628	629	630	631	632	633	634	635	636	637	638	639	
640	641	642	643	644	645	646	647	648	649	650	651	652	653	654	655	656	657	658	659	660	661	662	663	664	665	666	667	668	669	670	671	
672	673	674	675	676	677	678	679	680	681	682	683	684	685	686	687	688	689	690	691	692	693	694	695	696	697	698	699	700	701	702	703	
704	705	706	707	708	709	710	711	712	713	714	715	716	717	718	719	720	721	722	723	724	725	726	727	728	729	730	731	732	733	734	735	
736	737	738	739	740	741	742	743	744	745	746	747	748	749	750	751	752	753	754	755	756	757	758	759	760	761	762	763	764	765	766	767	
768	769	770	771	772	773	774	775	776	777	778	779	780	781	782	783	784	785	786	787	788	789	790	791	792	793	794	795	796	797	798	799	
800	801	802	803	804	805	806	807	808	809	810	811	812	813	814	815	816	817	818	819	820	821	822	823	824	825	826	827	828	829	830	831	
832	833	834	835	836	837	838	839	840	841	842	843	844	845	846	847	848	849	850	851	852	853	854	855	856	857	858	859	860	861	862	863	
864	865	866	867	868	869	870	871	872	873	874	875	876	877	878	879	880	881	882	883	884	885	886	887	888	889	890	891	892	893	894	895	
896	897	898	899	900	901	902	903	904	905	906	907	908	909	910	911	912	913	914	915	916	917	918	919	920	921	922	923	924	925	926	927	
928	929	930	931	932	933	934	935	936	937	938	939	940	941	942	943	944	945	946	947	948	949	950	951	952	953	954	955	956	957	958	959	
960	961	962	963	964	965	966	967	968	969	970	971	972	973	974	975	976	977	978	979	980	981	982	983	984	985	986	987	988	989	990	991	
992	993	994	995	996	997	998	999	1000	1001	1002	1003	1004	1005	1006	1007	1008	1009	1010	1011	1012	1013	1014	1015	1016	1017	1018	1019	1020	1021	1022	1023	

The electrical offset is sampled parallel for the top and bottom half. The matching lines for the corresponding electrical offsets and active Pixel are marked with the same color.

32x32d electrical Offset																															
0	1	2	3	4	5	6	7	8	9	10	11	12	13	14	15	16	17	18	19	20	21	22	23	24	25	26	27	28	29	30	31
32	33	34	35	36	37	38	39	40	41	42	43	44	45	46	47	48	49	50	51	52	53	54	55	56	57	58	59	60	61	62	63
64	65	66	67	68	69	70	71	72	73	74	75	76	77	78	79	80	81	82	83	84	85	86	87	88	89	90	91	92	93	94	95
96	97	98	99	100	101	102	103	104	105	106	107	108	109	110	111	112	113	114	115	116	117	118	119	120	121	122	123	124	125	126	127
128	129	130	131	132	133	134	135	136	137	138	139	140	141	142	143	144	145	146	147	148	149	150	151	152	153	154	155	156	157	158	159
160	161	162	163	164	165	166	167	168	169	170	171	172	173	174	175	176	177	178	179	180	181	182	183	184	185	186	187	188	189	190	191
192	193	194	195	196	197	198	199	200	201	202	203	204	205	206	207	208	209	210	211	212	213	214	215	216	217	218	219	220	221	222	223
224	225	226	227	228	229	230	231	232	233	234	235	236	237	238	239	240	241	242	243	244	245	246	247	248	249	250	251	252	253	254	255

5 Characteristics:

5.1 Common Specifications:

Technology	n-poly/p-poly Si
Element Resistance	approx. 300 kOhms
Sensitivity	approx. 450 V/W without optics and filter
Thermal pixel time constant	<4 ms
Digital Interface	I ² C
Analog Output	No
selectable Clock	1 to 13 MHz
EEPROM size	64 kBit

Pitch	90 μ m
Absorber size	77 μ m
Max. Framerate	60 Hz
(complete frame with maximum I ² C and sensor clock speed and reduced ADC resolution)	
1024 sensitive elements	

5.2 Optical characteristics:

Focal length:	2.1 mm ("L" equals the focal length of the lens)
F-Number:	0.8
Field of view:	90 x 90 deg
Lens coating:	AR-Coating; average reflectance per surface < 3% for $8\mu\text{m} < \lambda < 11.5\mu\text{m}$ Environment acc. for MIL-C-48497

HTPA32x32dL2.1/0.8

Thermopile Array With Lens Optics

Rev.8: 2016.04.12 Schnorr



5.3 Electric Specifications:

Absolute Maximum Ratings:

Parameter	Symbol	Condition	MIN.	TYP.	MAX.	Unit
Supply Voltage	V _{DD}		-0.3		3.6	V
Voltage at All inputs and outputs	V _{IO}		-0.3		V _{DD} +0.3	V
Storage Temperature	T _{STG}		-40		85	Deg. C

Operating Conditions:

Parameter	Symbol	Condition	MIN.	TYP.	MAX.	Unit
Supply Voltage	V _{DD}		3.3	3.35	3.6	V
Supply Current (sensor running)	I _{DD}		9.0	10.2	10.7	mA
Supply Current (sensor in idle state)	I _{DD}		8.5	9.6	10.2	mA
Standby Current (sensor in sleep state)	I _{SBY}		2.0	2.1	2.5	μA
Operation Temperature	T _A		-20		85	Deg. C
ESD-Protection		Human body model	2.0			kV
		100pF + 1k50hm				

Electrical Characteristics

Parameter	Symbol	Condition	MIN.	TYP.	MAX.	Unit
-----------	--------	-----------	------	------	------	------

Digital Input

Internal Clock frequency	F _{CLK}		1	5	13	MHz
Internal I ² C Pull up	R _{PU}		1	100	100	kOhm
Bias current	I _{BIAS}		1	5	13	μA
BPA current	I _{BPA}		0.2	1.5	4.0	μA
Input voltage high	V _{IH}		0.7xV _{DD}			V
Input voltage low	V _{IL}				0.3xV _{DD}	V

PTAT

Temperature range			TBD		TBD	Deg. C
PTAT gradient			170	174	178	K/V

HTPA32x32dL2.1/0.8

Thermopile Array With Lens Optics

Rev.8: 2016.04.12 Schnorr



Preamplifier / ADC

Parameter	Symbol	Condition	MIN.	TYP.	MAX.	Unit
Chopper frequency	F_{CHP}			20		kHz
Preamplifier Noise	N_{PA}	at 20 kHz		72		$\text{nV}/\text{HZ}^{1/2}$
Frame rate (Full Array)	FR1		2	9	60	Hz
Frame rate (Quarter Array)	FR4		8	36	240	HZ
ADC pos. Reference	V_{REFP}			1.6		V
ADC neg. Reference	V_{REFN}			0.9		V
ADC resolution	ADC_{LSB}	at 16 Bit		21		μV

6 I²C Timings HTPA32x32d:

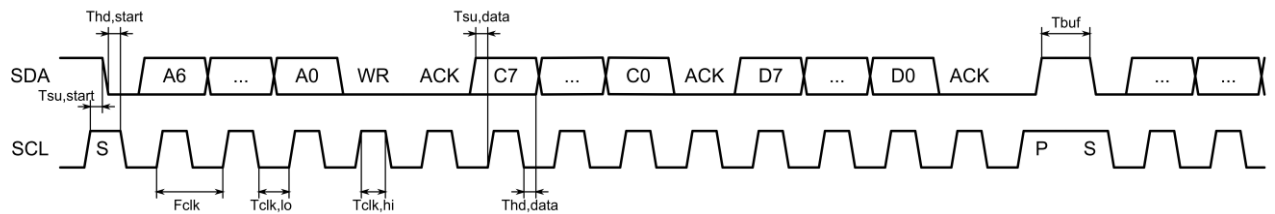

Parameter	Symbol	Condition	MIN.	TYP.	MAX.	Unit
I ² C clock frequency	F_{CLK}			400	1000	kHz
low pulse duration	$T_{\text{CLK,lo}}$		0.50			μs
high pulse duration	$T_{\text{CLK,hi}}$		0.26			μs
data set up time	$T_{\text{SU,data}}$		0.05			μs
data hold time	$T_{\text{hd,data}}$		0.00			μs
start setup time	$T_{\text{SU,start}}$		0.26			μs
start hold time	$T_{\text{hd,start}}$		0.26			μs
stop setup time	$T_{\text{SU,stop}}$		0.26			μs
stop hold time	$T_{\text{hd,stop}}$		0.26			μs
time between STOP / START	T_{buf}		0.50			μs

7 I²C Communication:

The chip uses the 7-bit I²C address 0x34 for configuration and sensor data and the address 0xA0 to access the internal EEPROM. The address byte is followed by an 8-bit command.

7.1 Write Command:

In case of a write access to an internal register the command is followed by the data byte. The chip acknowledges each byte with a low active ACK bit.

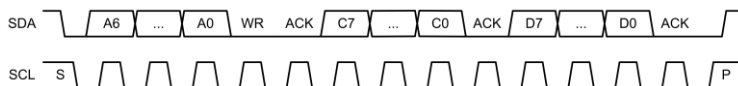

7.2 Read Command:

To read data from the chip first the address and command must be sent. After the last ACK a new start-bit (repeated start) and the address with a set read-flag initiates the read sequence. There can be bytes read as many as required. The last byte must be denoted by a not-acknowledge. The shown example below can be used e.g. to get the status register.

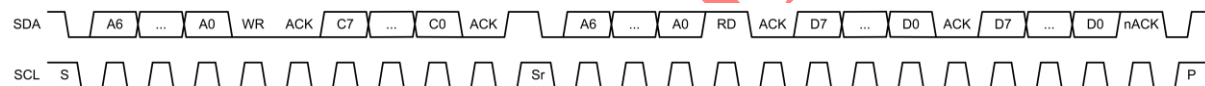

7.3 Sensor Commands:

The sensor has several registers that can be written and read, they are listed below.

Configuration register (write only)

Addr / CMD	0x34 / 0x01							
Config Reg	7	6	5	4	3	2	1	0
Name	RFU		BLOCK		START	RFU	BLIND	WAKEUP
Default	0	0	0	0	0	0	0	0

The WAKEUP bit is used to switch on / off the chip and must be set prior all other operations. After the START bit is set the chip starts a conversion of the array or blind elements and enters the idle state (not sleep!) when finished. The BLOCK selects one of the four multiplexed array blocks.

If the BLIND bit is set the electrical offsets are sampled instead of the active pixel and the setting of the BLOCK is ignored.

Status Register (read only)

Addr / CMD	0x34 / 0x02							
Status Reg	7	6	5	4	3	2	1	0
Name	RFU				BLOCK		RFU	EOC
Default	0	0	0	0	0	0	0	0

If the EOC flag is set a previous started conversion has been finished.

HTPA32x32dL2.1/0.8

Thermopile Array With Lens Optics

Rev.8: 2016.04.12 Schnorr



Trim Register 1 (write only)

Addr / CMD	0x34 / 0x03							
Trim Reg 1	7	6	5	4	3	2	1	0
Name	RFU				MBIT TRIM			
Default	0	0	0	0	1	1	0	0

MBIT_TRIM: $m = 4$ to $12 \Rightarrow (m+4)$ bit as ADC resolution (Default: $m=12$)

Trim Register 2 (write only)

Addr / CMD	0x34 / 0x04							
Trim Reg 2	7	6	5	4	3	2	1	0
Name	RFU				BIAS TRIM TOP			
Default	0	0	0	0	1	1	0	0

BIAS_TRIM_TOP: 0 to 31 $\Rightarrow 1\mu\text{A}$ to $13\mu\text{A}$ (Default: $5\mu\text{A}$)

This setting is used to adjust the bias current of the ADC. A faster clock frequency requires a higher bias current setting.

Trim Register 3 (write only)

Addr / CMD	0x34 / 0x05							
Trim Reg 3	7	6	5	4	3	2	1	0
Name	RFU				BIAS TRIM BOT			
Default	0	0	0	0	1	1	0	0

BIAS_TRIM_BOT: 0 to 31 $\Rightarrow 1\mu\text{A}$ to $13\mu\text{A}$ (Default: $5\mu\text{A}$)

This setting is used to adjust the bias current of the ADC. A faster clock frequency requires a higher bias current setting.

Trim Register 4 (write only)

Addr / CMD	0x34 / 0x06							
Trim Reg 4	7	6	5	4	3	2	1	0
Name	RFU				CLK TRIM			
Default	0	0	0	1	0	1	0	1

CLK_TRIM: 0 to 63 $\Rightarrow 1\text{MHz}$ to 13MHz (Default: 5MHz)

NOTE: The measure time depends on the clock frequency settings. One quarter frame takes about:

$$t_{FR4} = \frac{32 \cdot (2^{MBIT} + 4)}{F_{CLK}} \approx 27\text{ms} @ 5\text{MHz}$$

Trim Register 5 (write only)

Addr / CMD	0x34 / 0x07							
Trim Reg 5	7	6	5	4	3	2	1	0
Name	RFU				BPA TRIM TOP			
Default	0	0	0	0	1	1	0	0

BPA_TRIM_TOP: 0 to 31 $\Rightarrow 0.2\mu\text{A}$ to $4.0\mu\text{A}$ (Default: $1.5\mu\text{A}$)

This setting is used to adjust the common mode voltage of the preamplifier.

HTPA32x32dL2.1/0.8

Thermopile Array With Lens Optics

Rev.8: 2016.04.12 Schnorr



Trim Register 6 (write only)

Addr / CMD	0x34 / 0x08							
Trim Reg 6	7	6	5	4	3	2	1	0
Name	RFU				BPA TRIM BOT			
Default	0	0	0	0	1	1	0	0

BPA_TRIM_BOT: 0 to 31 \Rightarrow 0.2 μ A to 4.0 μ A (Default: 1.5 μ A)

This setting is used to adjust the common mode voltage of the preamplifier.

Trim Register 7 (write only)

Addr / CMD	0x34 / 0x09							
Trim Reg 7	7	6	5	4	3	2	1	0
Name	PU SDA TRIM				PU SCL TRIM			
Default	1	0	0	0	1	0	0	0

PU_SDA_TRIM: select internal pull up resistor on SDA (Default: 100kOhm)

PU_SCL_TRIM: select internal pull up resistor on SCL (Default: 100kOhm)

“1000” = 100 kOhm; “0100” = 50 kOhm; “0010” = 10 kOhm; “0001” = 1 kOhm

Read Data 1 Command (Top Half of Array)

Addr / CMD	0x34 / 0x0A							
Read Data	7	6	5	4	3	2	1	0
1. Byte / 2. Byte	PTAT 1 MSB / LSB							
3. Byte / 4. Byte	Pixel (0+BLOCK*128) MSB / LSB							
5. Byte / 6. Byte	Pixel (1+BLOCK*128) MSB / LSB							
...	...							
257. Byte / 258. Byte	Pixel (127+BLOCK*128) MSB / LSB							

Read Data 2 Command (Bottom Half of Array)

Addr / CMD	0x34 / 0x0B							
Read Data	7	6	5	4	3	2	1	0
1. Byte / 2. Byte	PTAT 2 MSB / LSB							
3. Byte / 4. Byte	Pixel (992-BLOCK*128) MSB / LSB							
5. Byte / 6. Byte	Pixel (993-BLOCK*128) MSB / LSB							
...	...							
65. Byte / 66. Byte	Pixel (1023-BLOCK*128) MSB / LSB							
67. Byte / 68. Byte	Pixel (960-BLOCK*128) MSB / LSB							
69. Byte / 70. Byte	Pixel (961-BLOCK*128) MSB / LSB							
...	...							
129. Byte / 130. Byte	Pixel (991-BLOCK*128) MSB / LSB							
131. Byte / 132. Byte	Pixel (928-BLOCK*128) MSB / LSB							
...	...							
257. Byte / 258. Byte	Pixel (927-BLOCK*128) MSB / LSB							

The complete sensor data must be read at once. If the communication fails somewhere in between, all successive data will be corrupted. The readout can be stopped anywhere by pausing the clock. A new initialized readout proceeds at this stopped byte by continuing the clock, but the index is reset when a new conversion has been started.

HEIMANN Sensor GmbH Contact / Customer Support
Maria-Reiche-Str. 1 Phone 49 (0) 6123 60 50 30
D-01109 Dresden / Germany Fax 49 (0) 6123 60 50 39

Internet
www.heimanssensor.com
mail: info@heimanssensor.com

HTPA32x32dL2.1/0.8

Thermopile Array With Lens Optics

Rev.8: 2016.04.12 Schnorr



If the bit for the electrical offsets (Bit 1 in Config 0x01) is set the electrical offsets are sampled and can be read similar to the active pixel:

Read Data electrical offsets (Top Half of Array)

Addr / CMD	0x34 / 0x0A							
Read Data	7	6	5	4	3	2	1	0
1. Byte / 2. Byte	PTAT 1 MSB / LSB							
3. Byte / 4. Byte	electrical offset (0) MSB / LSB							
5. Byte / 6. Byte	electrical offset (1) MSB / LSB							
...	...							
257. Byte / 258. Byte	electrical offset (127) MSB / LSB							

Read Data electrical offsets (Bottom Half of Array)

Addr / CMD	0x34 / 0x0B							
Read Data	7	6	5	4	3	2	1	0
1. Byte / 2. Byte	PTAT 2 MSB / LSB							
3. Byte / 4. Byte	electrical offset (224) MSB / LSB							
5. Byte / 6. Byte	electrical offset (225) MSB / LSB							
...	...							
65. Byte / 66. Byte	electrical offset (255) MSB / LSB							
67. Byte / 68. Byte	electrical offset (192) MSB / LSB							
...	...							
257. Byte / 258. Byte	electrical offset (159) MSB / LSB							

The complete sensor data must be read at once. If the communication fails somewhere in between, all successive data will be corrupted. The readout can be stopped anywhere by pausing the clock. A new initialized readout proceeds at this stopped byte by continuing the clock, but the index is reset when a new conversion has been started.

7.4 EEPROM communication

The built-in EEPROM (24AA64 from Microchip) consists of 8 blocks of 1K x 8-bit. The chip select of the EEPROM is set to 000 (A2 to A0). For further information please see the corresponding datasheet:

<http://ww1.microchip.com/downloads/en/DeviceDoc/21189f.pdf>

HTPA32x32dL2.1/0.8

Thermopile Array With Lens Optics

Rev.8: 2016.04.12 Schnorr



7.5 I²C Example Sequences – Init and Read Thermopile Array

(There should be a delay of at least 5 ms between the write of each Configuration Register)

	ADDR	R/W	CONFIG_REG	WAKEUP	
S	0x34	0	0x01	0x01	P

	ADDR	R/W	TRIM_REG1	MBIT_TRIM	
S	0x34	0	0x03	0x0C	P

	ADDR	R/W	TRIM_REG2	BIAS_TRIML	
S	0x34	0	0x04	0x0C	P

	ADDR	R/W	TRIM_REG3	BIAS_TRIMR	
S	0x34	0	0x05	0x0C	P

	ADDR	R/W	TRIM_REG4	CLK_TRIM	
S	0x34	0	0x06	0x14	P

	ADDR	R/W	TRIM_REG5	BPA_TRIML	
S	0x34	0	0x07	0x0C	P

	ADDR	R/W	TRIM_REG6	BPA_TRIMR	
S	0x34	0	0x08	0x0C	P

	ADDR	R/W	TRIM_REG7	PU_TRIM	
S	0x34	0	0x09	0x88	P

	ADDR	R/W	CONFIG_REG	START/WAKEUP	
S	0x34	0	0x01	0x09	P

	ADDR	R/W	STATUS_REG		ADDR	R/W	STATUS	
S	0x34	0	0x02	Sr	0x34	1	??	P

Wait 30 ms

	ADDR	R/W	STATUS_REG		ADDR	R/W	STATUS	
S	0x34	0	0x02	Sr	0x34	1	??	P

	ADDR	R/W	READ_DATA 1		ADDR	R/W	PTAT1 MSB	PTAT1 LSB	P0,0 MSB	P0,0 LSB	...	Pxy MSB	Pxy LSB	
S	0x34	0	0x0A	Sr	0x34	1	??	??	??	??	...	??	??	P

	ADDR	R/W	READ_DATA 2		ADDR	R/W	PTAT2 MSB	PTAT2 LSB	P0,0 MSB	P0,0 LSB	...	Pxy MSB	Pxy LSB	
S	0x34	0	0x0B	Sr	0x34	1	??	??	??	??	...	??	??	P

	ADDR	R/W	CONFIG_REG	SLEEP	
S	0x34	0	0x01	0x00	P

8 Temperature calculation

The object and ambient temperature can be calculated from the sensor output and the stored calibration data. The table below is showing an overview of the EEPROM.

32x32d	0x00	0x01	0x02	0x03	0x04	0x05	0x06	0x07	0x08	0x09	0x0A	0x0B	0x0C	0x0D	0x0E	0x0F
0x0000	PixC _{min} (float)			PixC _{max} (float)				gradScale					TN	epsilon		
0x0010											MBIT(calib)	BIAS(calib)	CLK(calib)	BPA(calib)	PU(calib)	
0x0020																
0x0030				PTAT-gradient (float)				PTAT-offset (float)								
0x0040																
0x0050																
0x0060	MBIT(user)	BIAS(user)	CLK(user)	BPA(user)	PU(user)											
0x0070	DeviceID															
0x0080	free to use															
...																
0x0730	free to use															
0x0740	ThGrad _{ij} stored as 16 bit signed values															
...																
0x0F30	ThOffset _{ij} stored as 16 bit signed values															
0x0F40	ThOffset _{ij} stored as 16 bit signed values															
...																
0x1730	P _i stored as 16 bit unsigned values															
0x1740	P _i stored as 16 bit unsigned values															
...																
0x1F30	P _i stored as 16 bit unsigned values															

All values are stored as unsigned 8 bit values unless they are specified otherwise. The little endian format is used for larger values. Grey marked areas are used during calibration or for future use and are Heimann Sensor reserved.

MBIT(calib), BIAS(calib), CLK(calib), BPA(calib) and PU(calib) are the settings for the registers that have been used during calibration (see chapter 7.3 on how to set them). MBIT(user), BIAS(user), CLK(user), BPA(user) and PU(user) are free to be set by the user. The temperature calculation is only valid if the same settings are used that have been set during calibration!

The corresponding order of the $ThGrad_{ij}$, $ThOffset_{ij}$ and P_{ij} to the Pixelnumber is given by the following overview:

ThGrad _{0,0} → Pixel 0	ThGrad _{0,1} → Pixel 1	...	ThGrad _{0,31} → Pixel 31
ThGrad _{1,0} → Pixel 32	ThGrad _{1,1} → Pixel 33	...	ThGrad _{1,31} → Pixel 63
...			
...			
ThGrad _{15,0} → Pixel 480	ThGrad _{15,1} → Pixel 481	...	ThGrad _{15,31} → Pixel 511
ThGrad _{16,0} → Pixel 992	ThGrad _{16,1} → Pixel 993	...	ThGrad _{16,31} → Pixel 1023
ThGrad _{17,0} → Pixel 960	ThGrad _{17,1} → Pixel 961	...	ThGrad _{17,31} → Pixel 991
...			
...			
ThGrad ₃₁₀ → Pixel 512	ThGrad ₃₁₁ → Pixel 513	...	ThGrad ₃₁₃₁ → Pixel 543

8.1 Ambient Temperature:

The ambient temperature (T_a) is calculated from the average measured PTAT value, the $PTAT_{gradient}$ and the $PTAT_{offset}$.

$$T_a = \frac{\sum_{i=0}^7 PTAT_i}{8} \cdot PTAT_{gradient} + PTAT_{offset} \quad (\text{Value is given back in dK})$$

where:

$PTAT_{gradient}$ is the gradient of the PTAT stored in the EEPROM as a float value

$PTAT_{offset}$ is the offset of the PTAT stored in the EEPROM as a float value

8.2 Thermal Offset:

The thermal offset of the sensor needs to be subtracted for each pixel to compensate for any thermal drifts.

$$V_{ij_Comp} = V_{ij} - \frac{ThGrad_{ij} \cdot Ta}{2^{gradScale}} - ThOffset_{ij}$$

where:

ij represents the row (i) and column (j) of the pixel

V_{ij_Comp} is the thermal offset compensated voltage

V_{ij} is the raw pixel data (digital), readout from the RAM

$ThGrad_{ij}$ is the thermal gradient, stored in the EEPROM from 0x740 to 0xF3F

$ThOffset_{ij}$ is the thermal offset, stored in the EEPROM from 0xF40 to 0x173F

$gradScale$ is the scaling coefficient for the thermal gradient

8.3 Electrical Offset

The electrical offset is used to compensate changes in the supply voltage. This compensation is only a subtraction so it can be done before or after the thermal offset compensation (here done afterwards).

The compensation for the top half is done by using the following formula:

$$V_{ij_Comp}^* = V_{ij_Comp} - elOffset[j + (i : 4) \cdot 32]$$

and the bottom half analogue with this formula:

$$V_{ij_Comp}^* = V_{ij_Comp} - elOffset[j + (i : 4) \cdot 32 + 128]$$

where:

ij represents the row (i) and column (j) of the pixel and electrical offset

$V_{ij_Comp}^*$ is the electrical offset compensated voltage

V_{ij_Comp} is the thermal offset compensated voltage

$elOffset[ij]$ is the electrical offset belonging to Pixel ij

$i : 4$ is the rest of the integer division of i by 4 (e.g. 7:4=3)

Please see chapter 4 for the serial order.

HTPA32x32dL2.1/0.8

Thermopile Array With Lens Optics

Rev.8: 2016.04.12 Schnorr



8.4 Object Temperature:

The calculation of the object temperature is done by using a look-up table and doing a bi-linear interpolation, the matching table is given by the tablenumber (TN). The table is supplied in a separate file named "Table.c".

The sensitivity coefficients ($PixC_{ij}$) are calculated in the following way:

$$PixC_{ij} = \left(\frac{P_{ij} \cdot (PixC_{max} - PixC_{min})}{65535} + PixC_{min} \right) \cdot \frac{100}{\epsilon}$$

where:

- $PixC_{ij}$ is the sensitivity coefficient for each pixel
- P_{ij} is the stored sensitivity coefficient scaled to 16 bit
- $PixC_{min}$ is the minimum sensitivity coefficient, used for scaling
- $PixC_{max}$ is the maximum sensitivity coefficient, used for scaling
- ϵ is the emissivity factor

Leading to a compensation of the pixel voltage

$$V_{ij_PixC} = \frac{V_{ij_Comp} \cdot PCSCALEVAL}{PixC_{ij}}$$

where:

- V_{ij_PixC} is the sensitivity compensated IR voltage
- $PCSCALEVAL$ is a scaling coefficient, typically $1 \cdot 10^8$

Preliminary

8.5 Example calculation:

Example values:

$$PTAT = 32357 \text{ Digits}$$

$$PTAT_{gradient} = 0.046 \text{ dK / Digit}$$

$$PTAT_{offset} = 1511.6 \text{ dK}$$

$$V_{00} = 34435 \text{ Digits}$$

$$gradScale = 15$$

$$ThGrad_{00} = 56693 \xrightarrow{\text{sign check}} -8842$$

$$ThOffset_{00} = 44$$

$$elOffset[0] = 35000$$

$$PixC_{00} = 1.1 \cdot 10^8$$

$$PCSCALEVAL = 1 \cdot 10^8$$

Calculation of ambient temperature:

$$Ta = PTAT \cdot PTAT_{gradient} + PTAT_{offset} = 32357 \cdot 0.046 + 1511.6 \text{ dK} = 3000 \text{ dK}$$

Compensation of thermal offset:

$$V_{00_Comp} = V_{00} - \frac{ThGrad_{00} \cdot Ta}{2^{gradScale}} - ThOffset_{00} = 34435 - \frac{-8842 \cdot 3000}{2^{15}} - 44 = 35200$$

Compensation of electrical offset:

$$V_{00_Comp}^* = V_{00_Comp} - elOffset[0] = 35200 - 35000 = 200$$

HTPA32x32dL2.1/0.8

Thermopile Array With Lens Optics

Rev.8: 2016.04.12 Schnorr



Example look-up table:

TA[dK]/dig	2882	3032	3182	3332
-64	1494	2128	2491	2775
-32	2466	2692	2898	3091
0	2882	3032	3182	3332
32	3170	3285	3406	3530
64	3396	3491	3592	3699
96	3584	3665	3754	3848
128	3746	3818	3897	3981
160	3890	3954	4025	4102
192	4019	4078	4143	4214
224	4137	4191	4251	4317
256	4246	4296	4351	4413
288	4347	4393	4445	4503
320	4441	4485	4534	4588

$$V_{00_PixC} = \frac{200 \cdot 1 \cdot 10^8}{1.1 \cdot 10^8} = 182$$

Ta was calculated before to 3000 dK.

The matching region in the look-up table is already marked yellow, the bi-linear interpolation is leading to an object temperature of 3941 dK = 120.9 °C.

Preliminary

8.6 Look-up Table

dia \ Ta(dK)	2782	2982	3082	3182	3282	3382
-256			1159	1804	2115	2343
-192			2211	2407	2576	2727
-128			2605	2742	2872	2995
-64			2873	2986	3097	3206
0	2782	2982	3082	3182	3282	3382
64	2993	3078	3166	3256	3347	3534
128	3167	3243	3322	3405	3491	3579
192	3316	3385	3459	3537	3619	3703
256	3448	3512	3582	3656	3734	3801
320	3565	3626	3693	3764	3840	3903
384	3673	3731	3794	3864	3938	4016
448	3771	3827	3889	3956	4029	4105
512	3863	3916	3977	4043	4114	4189
576	3948	4000	4059	4124	4194	4269
640	4028	4079	4137	4200	4270	4344
704	4104	4154	4210	4273	4342	4415
768	4176	4224	4280	4342	4410	4484
832	4244	4292	4346	4408	4476	4549
896	4309	4356	4410	4471	4538	4611
960	4371	4417	4471	4532	4599	4671
1024	4431	4476	4530	4590	4657	4729
1088	4488	4533	4586	4646	4713	4785
1152	4543	4588	4641	4700	4767	4839
1216	4597	4641	4693	4753	4819	4891
1280	4648	4692	4744	4803	4869	4941
1344	4698	4742	4793	4852	4918	4990
1408	4746	4790	4841	4900	4966	5038
1472	4793	4836	4888	4946	5012	5084
1536	4839	4881	4933	4991	5057	5129
1600	4883	4926	4977	5035	5101	5173
1664	4926	4968	5019	5078	5144	5216
1728	4968	5010	5061	5120	5185	5258
1792	5009	5051	5102	5160	5226	5298
1856	5049	5091	5142	5200	5266	5338
1920	5088	5130	5180	5239	5305	5377
1984	5126	5168	5218	5277	5343	5415
2048	5164	5205	5256	5314	5380	5452
2112	5200	5242	5292	5351	5417	5490
2176	5236	5277	5328	5386	5453	5526
2240	5271	5312	5363	5421	5488	5561
2304	5305	5347	5397	5456	5522	5595
2368	5339	5380	5431	5490	5556	5629
2432	5372	5413	5464	5523	5589	5663
2496	5405	5446	5496	5555	5622	5695
2560	5437	5478	5528	5587	5654	5728
2624	5468	5508	5558	5617	5685	5759
2688	5498	5538	5588	5647	5715	5787
2752	5529	5569	5619	5680	5747	5821
2816	5559	5600	5651	5710	5777	5852
2880	5588	5629	5680	5739	5806	5881
2944	5617	5658	5709	5768	5836	5910
3008	5646	5687	5737	5797	5864	5939
3072	5674	5715	5765	5825	5893	5968
3136	5701	5742	5793	5853	5920	5996
3200	5729	5770	5820	5880	5948	6023
3264	5756	5797	5847	5907	5975	6051
3328	5782	5823	5874	5934	6002	6078
3392	5808	5849	5900	5960	6028	6104
3456	5834	5875	5926	5986	6054	6130
3520	5859	5900	5951	6011	6080	6156
3584	5885	5926	5977	6037	6105	6182
3648	5909	5950	6001	6061	6131	6207
3712	5934	5975	6026	6086	6155	6232
3776	5958	5999	6050	6111	6180	6257
3840	5982	6023	6074	6135	6204	6281
3904	6006	6047	6098	6159	6228	6305
3968	6029	6070	6121	6182	6252	6329
4032	6052	6093	6145	6205	6275	6352
4096	6075	6116	6167	6228	6298	6376
4160	6097	6139	6190	6251	6321	6399
4224	6120	6161	6212	6274	6344	6421
4288	6142	6183	6235	6296	6366	6444
4352	6164	6205	6257	6318	6388	6466
4416	6185	6227	6278	6340	6410	6488
4480	6207	6248	6300	6361	6432	6510
4544	6228	6269	6321	6383	6453	6532
4608	6249	6290	6342	6404	6475	6553
4672	6269	6311	6363	6425	6496	6575
4736	6290	6332	6384	6446	6516	6596
4800	6310	6352	6404	6466	6537	6616
4864	6330	6372	6424	6486	6558	6637
4928	6350	6392	6444	6507	6578	6657
4992	6370	6412	6464	6527	6598	6678
5056	6390	6431	6484	6546	6618	6698
5120	6409	6451	6503	6565	6638	6718
5184	6428	6470	6523	6585	6657	6737
5248	6447	6489	6542	6605	6677	6757
5312	6466	6508	6561	6624	6696	6776
5376	6485	6527	6580	6643	6715	6795
5440	6504	6546	6598	6661	6734	6815
5504	6522	6564	6617	6680	6752	6833
5568	6540	6582	6635	6699	6771	6852
5632	6558	6600	6654	6717	6789	6871
5696	6576	6618	6672	6735	6808	6890
5760	6594	6636	6690	6753	6826	6907
5824	6612	6654	6707	6771	6844	6925
5888	6629	6672	6725	6789	6862	6944
5952	6647	6689	6742	6806	6879	6961
6016	6664	6706	6760	6824	6897	6979
6080	6681	6723	6777	6841	6914	6997
6144	6698	6741	6794	6858	6932	7014
6208	6715	6757	6811	6875	6949	7031
6272	6732	6774	6828	6892	6966	7049
6336	6748	6791	6845	6909	6983	7066
6400	6765	6807	6861	6926	7000	7083
6464	6781	6824	6878	6942	7016	7100
6528	6797	6840	6894	6959	7033	7116
6592	6813	6856	6910	6975	7050	7133
6656	6830	6872	6927	6991	7066	7149
6720	6845	6888	6943	7007	7082	7166
6784	6861	6904	6958	7023	7098	7182

6848	6977	6920	6974	7039	7114	7198	7280
6912	6992	6936	6990	7055	7130	7214	7296
6976	6998	6951	7006	7071	7146	7230	7312
7040	6923	6966	7021	7086	7162	7246	7328
7104	6939	6982	7036	7102	7177	7262	7354
7168	6954	6997	7052	7117	7193	7277	7370
7232	6969	7012	7067	7133	7208	7293	7386
7296	6984	7027	7082	7148	7223	7308	7401
7360	6999	7042	7097	7163	7239	7324	7417
7424	7014	7057	7112	7178	7254	7339	7432
7488	7028	7072	7127	7193	7269	7354	7447
7552	7043	7086	7141	7207	7284	7369	7462
7616	7057	7101	7156	7222	7298	7384	7478
7680	7072	7115	7171	7237	7313	7399	7493
7744	7086	7130	7185	7251	7328	7414	7507
7808	7100	7144	7199	7266	7342	7428	7522
7872	7114	7158	7214	7280	7357	7443	7537
7936	7129	7172	7228	7294	7371	7457	7552
8000	7143	7186	7242	7309	7386	7472	7566
8064	7156	7200	7256	7323	7400	7486	7581
8128	7170	7214	7270	7337	7414	7500	7595
8192	7184	7228	7284	7351	7428	7515	7609
8256	7198	7242	7298	7365	7442	7529	7624
8320	7211	7255	7311	7378	7456	7543	7638
8384	7225	7269	7325	7392	7470	7557	7652
8448	7238	7282	7338	7406	7483	7570	7666
8512	7252	7296	7352	7419	7497	7584	7680
8576	7265	7309	7365	7433	7511	7598	7694
8640	7278	7322	7379	7446	7524	7612	7708
8704	7291	7336	7392	7460	7538	7626	7721
8768	7304	7349	7405	7473	7551	7639	7735
8832	7317	7362	7418	7486	7564	7652	7748
8896	7330	7375	7431	7499	7578	7666	7762
8960	7343	7388	7444	7512	7591	7679	7775
9024	7356	7401	7457	7525	7604	7692	7789
9088	7369	7413	7470	7538	7617	7705	7802
9152	7382	7426	7483	7551	7630	7718	7815
9216	7394	7439	7496	7564	7643	7731	7828
9280	7407	7451	7508	7577	7656	7744	7841
9344	7419	7464	7521	7589	7668	7757	7854
9408	7432	7476	7533	7602	7681	7770	7867
9472	7444	7489	7546	7614	7694	7783	7880
9536	7456	7501	7558	7627	7706	7795	7893
9600	7468	7513	7571	7639	7719	7808	7906
9664	7481	7526	7583	7652	7731	7821	7919
9728	7493	7538	7595	7664	7744	7833	7931
9792	7505	7550	7607	7676	7756	7846	7944
9856	7517	7562	7619	7688	7768	7858	7956
9920	7529	7574	7631	7701	7781	7871	7969
9984	7541	7586	7643	7713	7793	7883	7981
10048	7553	7598	7655	7725	7805	7895	7994
10112	7564	7610	7667	7737	7817	7907	8006
10176	7576	7621	7679	7749	7829	7919	8018
10240	7588	7633	7691	7760	7841	7931	8030
10304	7599	7645	7703	7772	7853	7943	8042
10368	7611	7656	7714	7784	7865	7955	8055
10432	7622	7668	7726	7796	7876	7967	8067
10496	7634	7679	7737	7807	7888	7979	8078
10560	7645	769					

HTPA32x32dL2.1/0.8

Thermopile Array With Lens Optics

Rev.8: 2016.04.12 Schnorr



14016	8197	8245	8306	8380	8465	8562	8667
14080	8206	8254	8315	8389	8475	8571	8677
14144	8216	8263	8325	8399	8484	8581	8687
14208	8225	8272	8334	8408	8494	8590	8696
14272	8234	8282	8343	8417	8503	8600	8706
14336	8243	8291	8352	8426	8512	8609	8715
14400	8252	8300	8361	8436	8522	8618	8725
14464	8261	8309	8371	8445	8531	8628	8734
14528	8270	8318	8380	8454	8540	8637	8744
14592	8279	8327	8389	8463	8549	8646	8753
14656	8288	8336	8398	8472	8559	8656	8762
14720	8297	8345	8407	8481	8568	8665	8771
14784	8306	8354	8416	8490	8577	8674	8781
14848	8315	8363	8425	8499	8586	8683	8790
14912	8323	8372	8434	8508	8595	8692	8800
14976	8332	8380	8442	8516	8603	8700	8809
15040	8341	8389	8451	8525	8612	8709	8818
15104	8350	8398	8460	8535	8622	8719	8827
15168	8358	8407	8469	8544	8631	8728	8836
15232	8367	8416	8478	8553	8640	8738	8845
15296	8376	8424	8487	8562	8649	8747	8855
15360	8384	8433	8495	8570	8658	8756	8864
15424	8393	8442	8504	8579	8666	8765	8873
15488	8402	8450	8513	8588	8675	8774	8882
15552	8410	8459	8521	8597	8684	8782	8891
15616	8419	8467	8530	8605	8692	8791	8900
15680	8427	8476	8538	8614	8702	8800	8908
15744	8436	8484	8547	8623	8710	8809	8917
15808	8444	8493	8556	8631	8719	8818	8926
15872	8453	8501	8564	8640	8728	8826	8935
15936	8461	8510	8573	8648	8736	8835	8944
16000	8469	8518	8581	8657	8745	8844	8953
16064	8478	8527	8590	8665	8753	8852	8961
16128	8486	8535	8598	8674	8762	8861	8970
16192	8494	8543	8606	8682	8771	8870	8979
16256	8503	8552	8615	8691	8779	8878	8988
16320	8511	8560	8623	8699	8788	8887	8996
16384	8519	8568	8631	8708	8796	8895	9005
16448	8527	8576	8640	8716	8804	8904	9013
16512	8536	8585	8648	8724	8813	8912	9022
16576	8544	8593	8656	8733	8821	8921	9031
16640	8552	8601	8664	8741	8830	8929	9039
16704	8560	8609	8673	8749	8838	8938	9048
16768	8568	8617	8681	8757	8846	8946	9056
16832	8576	8626	8689	8766	8854	8954	9065
16896	8584	8634	8697	8774	8863	8963	9073
16960	8592	8642	8705	8782	8871	8971	9081
17024	8600	8650	8713	8790	8879	8979	9090
17088	8608	8658	8721	8798	8887	8988	9098
17152	8616	8666	8729	8806	8896	8996	9106
17216	8624	8674	8737	8814	8904	9004	9115
17280	8632	8682	8745	8822	8912	9012	9125
17344	8640	8690	8753	8831	8920	9021	9131
17408	8648	8697	8761	8839	8928	9029	9140
17472	8656	8705	8769	8847	8936	9037	9148
17536	8664	8713	8777	8854	8944	9045	9156
17600	8671	8721	8785	8862	8952	9053	9164
17664	8679	8729	8793	8870	8960	9061	9172
17728	8687	8737	8801	8878	8968	9069	9181
17792	8695	8745	8809	8886	8976	9077	9189
17856	8703	8753	8816	8894	8984	9085	9197
17920	8710	8760	8824	8902	8992	9093	9206
17984	8718	8768	8832	8910	9000	9101	9214
18048	8725	8775	8840	8917	9008	9109	9221
18112	8733	8783	8847	8925	9016	9117	9229
18176	8741	8791	8855	8933	9023	9125	9237
18240	8748	8798	8863	8941	9031	9133	9245
18304	8756	8806	8871	8949	9039	9141	9253
18368	8764	8814	8878	8956	9047	9149	9261
18432	8771	8821	8886	8964	9055	9157	9269
18496	8779	8829	8893	8972	9062	9164	9277
18560	8786	8836	8901	8979	9070	9172	9286
18624	8794	8844	8909	8987	9078	9180	9292
18688	8801	8851	8916	8994	9085	9188	9300
18752	8808	8859	8924	9002	9093	9195	9308
18816	8816	8866	8931	9010	9101	9203	9316
18880	8823	8874	8939	9017	9108	9211	9324
18944	8831	8881	8946	9025	9116	9218	9331
19008	8838	8889	8954	9032	9123	9226	9339
19072	8845	8896	8961	9040	9131	9234	9347
19136	8853	8903	8968	9047	9138	9241	9354
19200	8860	8911	8976	9055	9146	9249	9362
19264	8867	8918	8983	9062	9153	9256	9370
19328	8875	8925	8991	9069	9161	9264	9377
19392	8882	8933	8998	9077	9168	9272	9385
19456	8889	8940	9005	9084	9176	9279	9393
19520	8896	8947	9013	9092	9183	9287	9401
19584	8903	8954	9020	9100	9191	9294	9408
19648	8911	8962	9027	9108	9198	9302	9415
19712	8918	8969	9034	9114	9205	9309	9423
19776	8925	8976	9042	9121	9213	9316	9430
19840	8932	8983	9049	9128	9220	9324	9438
19904	8939	8990	9056	9135	9228	9331	9445
19968	8947	8998	9063	9143	9235	9339	9453
20032	8954	9005	9070	9150	9242	9346	9460
20096	8961	9013	9077	9157	9249	9353	9467
20160	8968	9020	9085	9164	9257	9361	9475
20224	8975	9026	9092	9171	9264	9368	9483
20288	8982	9033	9099	9179	9271	9375	9490
20352	8989	9040	9106	9186	9278	9383	9497
20416	8996	9047	9113	9193	9285	9390	9505
20480	9003	9054	9120	9200	9293	9397	9512
20544	9010	9061	9127	9207	9300	9404	9519
20608	9017	9068	9134	9214	9307	9411	9527
20672	9024	9075	9141	9221	9314	9419	9534
20736	9031	9082	9148	9228	9321	9426	9541
20800	9038	9089	9155	9235	9328	9433	9548
20864	9044	9096	9162	9242	9335	9440	9555
20928	9051	9103	9169	9249	9342	9447	9563
20992	9058	9110	9176	9256	9349	9454	9570
21056	9065	9116	9183	9263	9356	9461	9577
21120	9072	9123	9190	9270	9363	9469	9584
21184	9079	9130	9197	9277	9370	9476	9591
21248	9085	9137	9203	9284	9377	9483	9598
21312	9092	9144	9210	9291	9384	9490	9606
21376	9099	9151	9217	9298	9391	9497	9613
21440	9106	9157	9224	9305	9398	9504	9620
21504	9112	9164	9231	9311	9405	9511	9627
21568	9119	9171	9238	9318	9412	9518	9634
21632	9126	9178	9244	9325	9419	9525	9641
21696	9132	9184	9251	9332	9426	9532	9648
21760	9139	9191	9258	9339	9433	9538	9655
21824	9146	9198	9264	9345	9439	9545	9662
21888	9152	9204	9271	9352	9446	9552	9669

21952	9159	9211	9278	9359	9453	9559	9676
22016	9166	9218	9285	9366	9460	9566	9683
22080	9172	9224	9291	9372	9467	9573	9690
22144	9179	9231	9298	9379	9473	9579	9697
22208	9185	9237	9305	9386	9480	9586	9703
22272	9192	9244	9311	9393	9487	9593	9710
22336	9199	9251	9318	9399	9494	9600	9717
22400	9205	9257	9324	9406	9500	9607	9724
22464	9212	9264	9331	9413	9507	9614	9731
22528	9218	9270	9338	9419	9514	9620	9738
22592	9225	9277	9344	9426	9520	9627	9745
22656	9231	9283	9351	9432	9527	9634	9751
22720	9237	9290	9357	9439	9534	9641	9758
22784	9244	9296	9364	9445	9540	9647	9765
22848	9250	9303	9370	9452	9547	9654	9772
22912	9257	9309	9377	9458	9554	9661	9778
22976	9263	9316	9383	9465	9560	9667	9785
23040	9270	9322	9390	9472	9567	9674	9792
23104	9276	9328	9396	9478	9573	9680	9799
23168	9282	9335	9402	9485	9580	9687	9805
23232	9289	9341	9409	9491	9586	9694	9812
23296	9295	9348	9415	9497	9593	9700	9819
23360	9301	9354	9422	9504	9599	9707	9825
23424	9308	9360	9428	9510	9606	9713	9832
23488	9314	9367	9434	9517	9612	9720	9838
23552	9320	9373	9441	9523	9619	9726	9845
23616	9327	9379	9447	9530	9625	9733	9852
23680	9333	9385	9453	9536	9632	9739	9858
23744	9339	9392	9460	9542	9638	9746	9865
23808	9345	9398	9466	9549	9644	9752	9871
23872	9351	9404	9472	9555	9651	9759	9878
23936	9358	9410	9479	9561	9657	9765	9

9 Outer Dimensions:

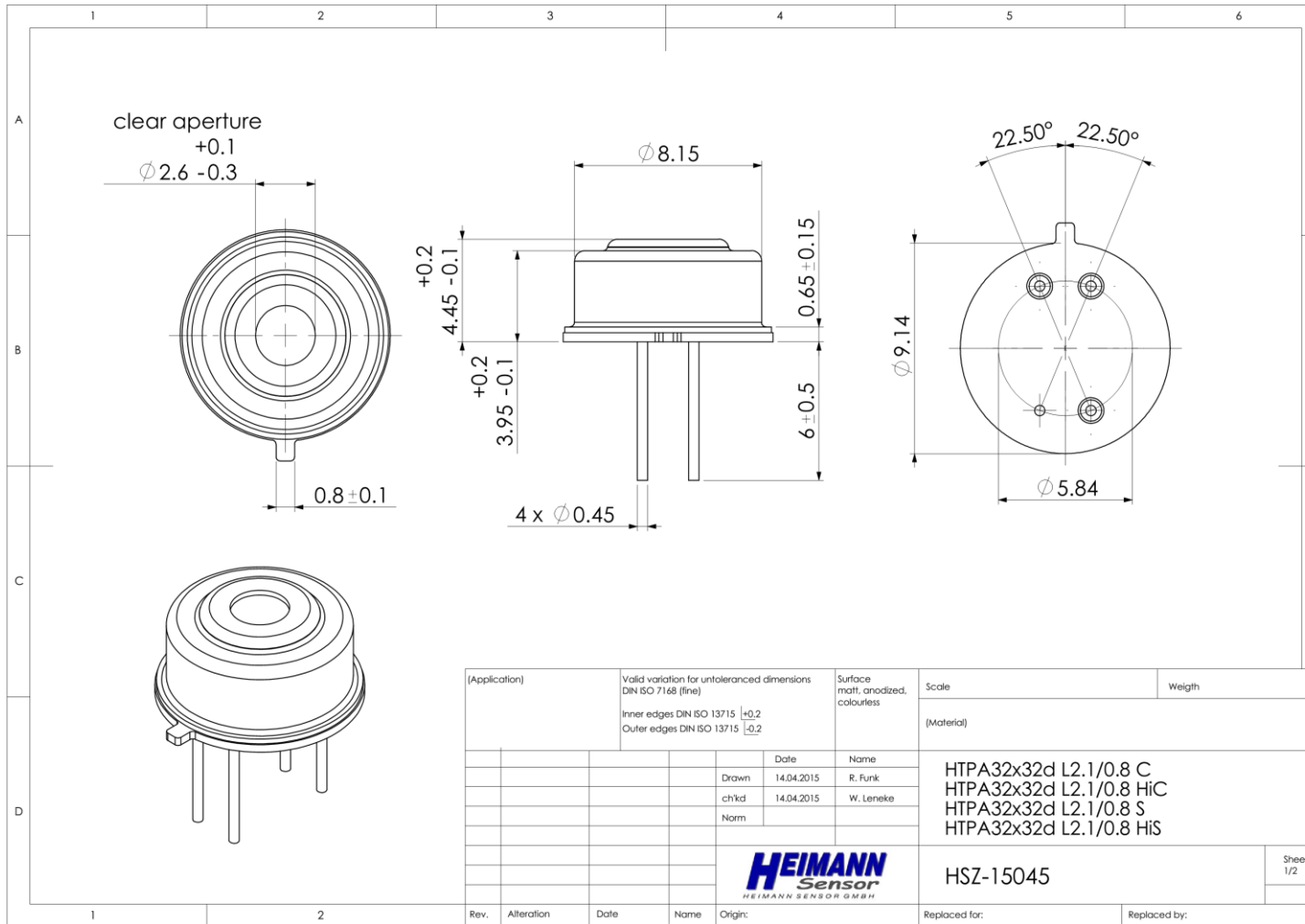

HEIMANN Sensor GmbH Contact / Customer Support
 Maria-Reiche-Str. 1 Phone 49 (0) 6123 60 50 30
 D-01109 Dresden / Germany Fax 49 (0) 6123 60 50 39

Internet
www.heimanssensor.com
 mail: info@heimanssensor.com